



*Culligan®  
Commercial  
Reverse Osmosis  
Water Systems*

*assisted living facilities*

*cafeterias*

*casinos*

*corporate campuses*

*educational facilities*

*food service*

*grocery*

*hotel/hospitality*

*institutions*

*laundry*

*theme parks*

*vehicle wash*

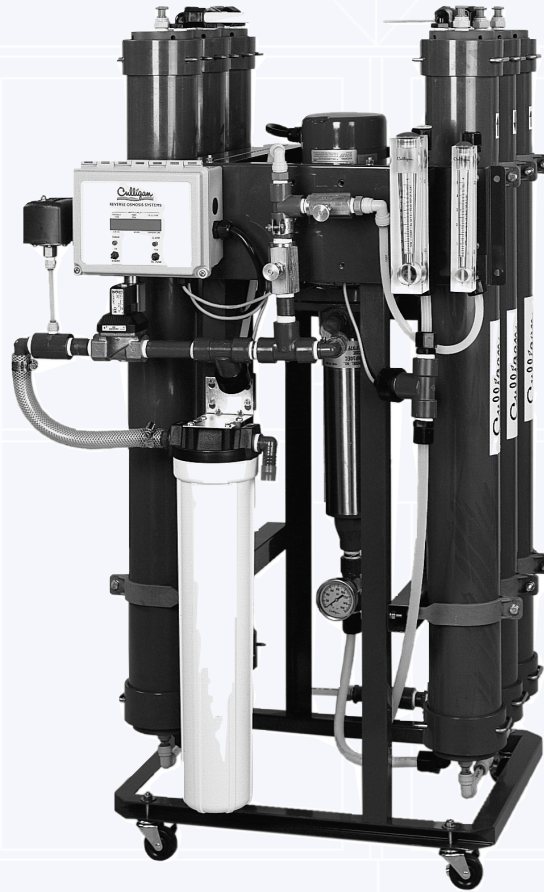

## The Culligan Series A and A Plus Reverse Osmosis System

The Economical Water Treatment Solution

### Series A and A Plus Standard Features

- Thin Film Composite RO Membranes—Rejects significant amounts of dissolved minerals, as well as colloids, particles, organics and silica.\*
- PVC/Module Housing—Corrosion resistant for long life.
- Multi-Stage Centrifugal Pump & Motor System—Optimum energy efficiency and quiet operation.
- Concentrate Recirculation—Saves water.
- Expandable Design—Serves water needs up to 10,000 gpd.
- Cartridge Prefiltration—Includes a replaceable 5-micron element that removes suspended particles to extend component life.
- Pressure Indicator—Displays system operating pressure.

\* Do not use with water that is microbiologically unsafe or of unknown quality without adequate disinfection before or after system.

(AF-6 Plus Model Shown. Wheels not included.)

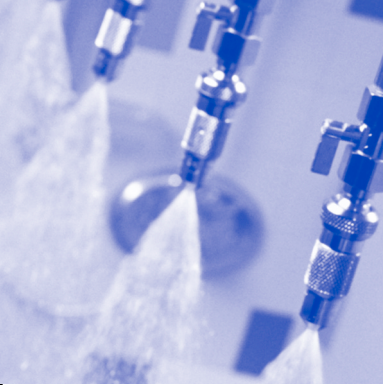

# The Culligan Series A and A Plus

## Applications and Benefits

- Food & Beverage—Superior taste and increased cost savings.
- Ice Production/Drinking Water—Reduces scaling; improves taste and clarity.
- Restaurants—Improves steamer operation.
- Humidification—Reduces scaling and dusting.
- Grocery Stores—Prevents scaling in vegetable misters.
- Pretreatment—For use in deionization systems.
- Boilers—Improves energy efficiency.
- Vehicle Wash—Provides spot-free rinses.
- Water Jet Cutting—Improves operating efficiency; extends orifice life.

## Series A and A Plus Standard Features

- Low Pressure Switch—Protects the pump during low feed water pressure conditions.
- Connection for Pretreatment Signal Switch and Level Control—Allows for easy integration and system operation.
- System Indicator Lights—Visually displays system operation or alarm conditions.
- Wall Mounting Bracket—For easy installation.
- Optional* • Sturdy Frame Mount Stand—Eliminates the need for mounting brackets.

## Series A Plus Standard Features

- A NEMA 4X enclosure—Contains a state-of-the-art electronic controller with backlit alphanumeric LCD display.
- TDS Monitor controls the product water quality and displays the feed TDS, product TDS and percent rejection.
- An elapsed time monitor to determine scheduled maintenance.
- A visual and audible alarm for indicating low pressure shut down and poor product water quality conditions.
- Panel mounted flow control indicators for effective monitoring of system performance.
- Concentrate throttling valve allows changes in system recovery to suit specific applications.
- Automatic low pressure flush feature to extend membrane life.

## System Specifications

|                                  |                           |
|----------------------------------|---------------------------|
| Inlet Pressure (dynamic):        | 20–50 psig<br>138–345 kPa |
| Operating Pressure:              | 120–150 psig              |
| Power:                           | 230V/60 Hz/1P             |
| Temperature:                     | 33–100°F<br>1–38°C        |
| Turbidity, max.:                 | 1 NTU                     |
| pH Range:                        | 3–11                      |
| Chlorine, max.:                  | 0 mg/L                    |
| Total Dissolved Solids, max.:    | 2500 mg/L                 |
| Silt Density Index, max.:        | 3                         |
| Langlier Saturation Index, max.: | 0                         |
| Iron, max.:                      | 0.1 mg/L                  |

## Model Descriptions

| Model    | Nominal Capacity** (GPD) | Approx. Recovery (%) | Motor HP | Approx. Operating Weight (lb) |
|----------|--------------------------|----------------------|----------|-------------------------------|
| A-1      | 2,000                    | 50                   | 1        | 130                           |
| A-1 Plus |                          |                      |          |                               |
| A-2      | 4,000                    | 50                   |          | 153                           |
| A-2 Plus |                          |                      |          |                               |
| A-3      | 5,800                    | 60                   |          | 176                           |
| A-3 Plus |                          |                      |          |                               |
| A-4      | 7,500                    | 60                   |          | 207                           |
| A-4 Plus |                          |                      |          |                               |
| A-5      | 9,000                    | 75                   |          | 230                           |
| A-5 Plus |                          |                      |          |                               |
| A-6      | 10,000                   | 75                   |          | 253                           |
| A-6 Plus |                          |                      |          |                               |

\*\* Approximate initial capacity based on properly pretreated feed water of 600 ppm TDS as NaCl, 77°F, Silt Density Index below 3, and 225 psi applied pressure supplying water to atmosphere. Productivity will vary depending on the feed water conditions.

“Hey Culligan Man!”®

**Culligan**

Culligan Commercial @ Work™

[www.culligan.com](http://www.culligan.com)™

1-800-CULLIGAN  
©2001 Culligan International Co.  
SL-0033-A DCO 993036  
Printed in USA (10/01)  
MOORE PART NO. 46917



Products manufactured and marketed by Culligan International Company (Culligan) and its affiliates are protected by patents issued or pending in the United States and other countries. Culligan reserves the right to change the specifications referred to in this literature at any time, without prior notice. Culligan, Hey Culligan Man, Culligan Man, Culligan Commercial @ Work, www.culligan.com and Culligan Service Network are trademarks of Culligan International Company or its affiliates.

# SERIES A AND A PLUS

## REVERSE OSMOSIS SYSTEMS

### SPECIFICATIONS AND OPERATING DATA

| MODELS                       |                  | A-1        | A-2        | A-3        | A-4        | A-5        | A-6        |
|------------------------------|------------------|------------|------------|------------|------------|------------|------------|
| Capacity                     | gpd <sup>1</sup> | 2,000      | 4,000      | 5,800      | 7,500      | 9,000      | 10,000     |
|                              | L/day            | 7,570      | 15,100     | 22,000     | 28,400     | 34,100     | 37,900     |
| Recovery % <sup>2</sup>      |                  | 50         | 50         | 60         | 60         | 75         | 75         |
| Motor                        | HP (kw)          | 1 (0.75)   | 1 (0.75)   | 1 (0.75)   | 1 (0.75)   | 1 (0.75)   | 1 (0.75)   |
| Elements 4" x 40" Qty.       |                  | 1          | 2          | 3          | 4          | 5          | 6          |
| Connections                  |                  |            |            |            |            |            |            |
| Feed, NPT                    | in               | 3/4        | 3/4        | 3/4        | 3/4        | 3/4        | 3/4        |
| Product, Tube                | in               | 1/2        | 1/2        | 1/2        | 5/8        | 5/8        | 5/8        |
| Concentrate, Tube**          | in               | 1/4        | 1/4        | 1/4        | 1/4        | 1/4        | 1/4        |
| Dimensions, Pump Assembly    |                  |            |            |            |            |            |            |
| Width                        | in (m)           | 35 (0.89)  | 35 (0.89)  | 35 (0.89)  | 35 (0.89)  | 35 (0.89)  | 35 (0.89)  |
| Depth                        | in (m)           | 10 (0.25)  | 10 (0.25)  | 10 (0.25)  | 10 (0.25)  | 10 (0.25)  | 10 (0.25)  |
| Height                       | in (m)           | 7 (0.18)   | 7 (0.18)   | 7 (0.18)   | 7 (0.18)   | 7 (0.18)   | 7 (0.18)   |
| Operating Weight             | lbs (kg)         | 36 (16.3)  | 36 (16.3)  | 36 (16.3)  | 36 (16.3)  | 36 (16.3)  | 36 (16.3)  |
| Dimensions, Control Assembly |                  |            |            |            |            |            |            |
| Width                        | in (m)           | 28 (0.71)  | 28 (0.71)  | 28 (0.71)  | 28 (0.71)  | 28 (0.71)  | 28 (0.71)  |
| Depth                        | in (m)           | 6 (0.15)   | 6 (0.15)   | 6 (0.15)   | 6 (0.15)   | 6 (0.15)   | 6 (0.15)   |
| Height                       | in (m)           | 18 (0.46)  | 18 (0.46)  | 18 (0.46)  | 18 (0.46)  | 18 (0.46)  | 18 (0.46)  |
| Operating Weight             | lbs (kg)         | 22 (9.9)   | 22 (9.9)   | 22 (9.9)   | 22 (9.9)   | 22 (9.9)   | 22 (9.9)   |
| Dimensions, Module Assembly  |                  |            |            |            |            |            |            |
| Width                        | in (m)           | 49 (1.24)  | 49 (1.24)  | 49 (1.24)  | 49 (1.24)  | 49 (1.24)  | 49 (1.24)  |
| Depth                        | in (m)           | 8 (0.20)   | 8 (0.20)   | 8 (0.20)   | 8 (0.20)   | 8 (0.20)   | 8 (0.20)   |
| Height                       | in (m)           | 19 (0.48)  | 19 (0.48)  | 19 (0.48)  | 38 (0.97)  | 38 (0.97)  | 38 (0.97)  |
| Operating Weight             | lbs (kg)         | 31 (14.1)  | 54 (24.5)  | 77 (34.9)  | 108 (49.0) | 131 (59.4) | 154 (69.8) |
| Dimensions, Frame Mounted    |                  |            |            |            |            |            |            |
| Width                        | in (m)           | 30 (0.76)  | 30 (0.76)  | 30 (0.76)  | 30 (0.76)  | 30 (0.76)  | 30 (0.76)  |
| Depth                        | in (m)           | 26 (0.66)  | 26 (0.66)  | 26 (0.66)  | 26 (0.66)  | 26 (0.66)  | 26 (0.66)  |
| Height                       | in (m)           | 50 (1.27)  | 50 (1.27)  | 50 (1.27)  | 50 (1.27)  | 50 (1.27)  | 50 (1.27)  |
| Operating Weight             | lbs (kg)         | 130 (59.0) | 153 (69.4) | 176 (79.8) | 207 (93.9) | 230 (104)  | 253 (115)  |

1 Nominal initial capacity based on properly pretreated feed water of 600 mg/L TDS, temperature of 77°F, pressure of 140 psi and Silt Density Index below 3.0. Productivity will vary depending on other feed water conditions.

2 Depending on feed water quality, it may be possible to operate any unit at a higher recovery to reduce operating costs. Refer to a printout from the Culligan CAAP<sup>®</sup> (Computer Aided Application Program) software, which indicates maximum allowable recovery.

\*\* Series A Plus unit operates with a 1/2" concentrate connection.

**Culligan**

Commercial Systems  
 ©2000 Culligan  
 1-800-CULLIGAN  
 www.culligan.com  
 Printed in USA Rev. 4/00  
 DCO 992587  
 SL-0080





# LIMITED WARRANTY

## COMMERCIAL/INDUSTRIAL REVERSE OSMOSIS SYSTEMS

You have just purchased one of the finest reverse osmosis water conditioning units made. As an expression of our confidence in Culligan products, your reverse osmosis water conditioning unit is warranted to the original end-user, when installed in accordance with Culligan International Company specifications, against defects in material and workmanship from the date of original installation, as follows:

**For a period of ONE YEAR** { **The entire reverse osmosis conditioning unit, including the reverse osmosis modules, but excluding the expendable filter cartridges used in this unit.**

If a part described above becomes defective, within the specified period, you should notify your independently operated Culligan dealer and arrange a time during normal business hours for the dealer to inspect the reverse osmosis unit on your premises. Any part found defective within the terms of this warranty will be repaired or replaced by the dealer. You pay only freight from our factory and local dealer charges.

Of course, damage caused by accident, fire, flood, freezing, Act of God, misuse, misapplication, neglect, alteration, installation or operation contrary to our printed instructions, or by the use of accessories or components which do not meet Culligan specifications, is not covered by this warranty.

Our product performance specifications are furnished with each water conditioning unit. TO THE EXTENT PERMITTED BY LAW, CULLIGAN DISCLAIMS ALL IMPLIED WARRANTIES INCLUDING, WITHOUT LIMITATION, WARRANTIES OF MERCHANTABILITY AND FITNESS FOR PARTICULAR PURPOSE; TO THE EXTENT REQUIRED BY LAW, ANY SUCH IMPLIED WARRANTIES ARE LIMITED IN DURATION TO THE ONE-YEAR PERIOD SPECIFIED ABOVE FOR THE PARTS DESCRIBED IN THIS LIMITED WARRANTY. As manufacturer, we do not know the characteristics of your water supply or the purpose for which you are purchasing a water conditioner. Please understand that the quality of water supplies may vary seasonally or over a period of time, and that your water usage rate may vary as well. Water characteristics can also change considerably if your water conditioner is moved to a new location. For these reasons, we assume no liability for the determination of the proper equipment necessary to meet your requirements, and we do not authorize others to assume such obligations for us. Further, we assume no liability and extend no warranties, express or implied, for the use of this product on a non-potable water source. OUR OBLIGATIONS UNDER THIS WARRANTY ARE LIMITED TO THE REPAIR OR REPLACEMENT OF THE FAILED PARTS OF THE WATER CONDITIONER, AND WE ASSUME NO LIABILITY WHATSOEVER FOR DIRECT, INCIDENTAL, CONSEQUENTIAL, SPECIAL, GENERAL, OR OTHER DAMAGES, WHETHER FROM CORROSION OR OTHER CAUSES.

### CONSUMERS:

Some states do not allow limitations on how long an implied warranty lasts, so the above limitation may not apply to you. Similarly, some states do not allow the exclusion of incidental or consequential damages, so the above limitation or exclusion may not apply to you. This warranty gives you specific legal rights, and you may also have other rights which vary from state to state. Consult your telephone directory for your local independently-operated Culligan dealer, or write Culligan International Company, for warranty and service information.

**CULLIGAN INTERNATIONAL COMPANY  
One Culligan Parkway  
Northbrook, Illinois 60062**

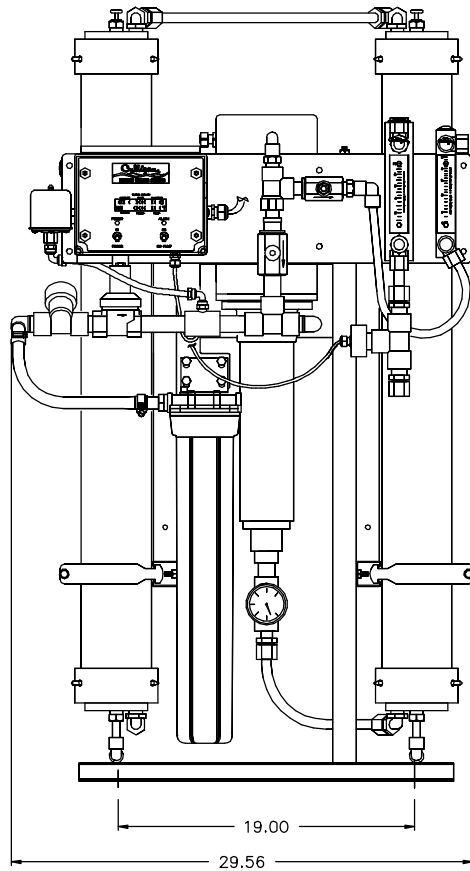

AF-6 PLUS SHOWN (FRONT VIEW)

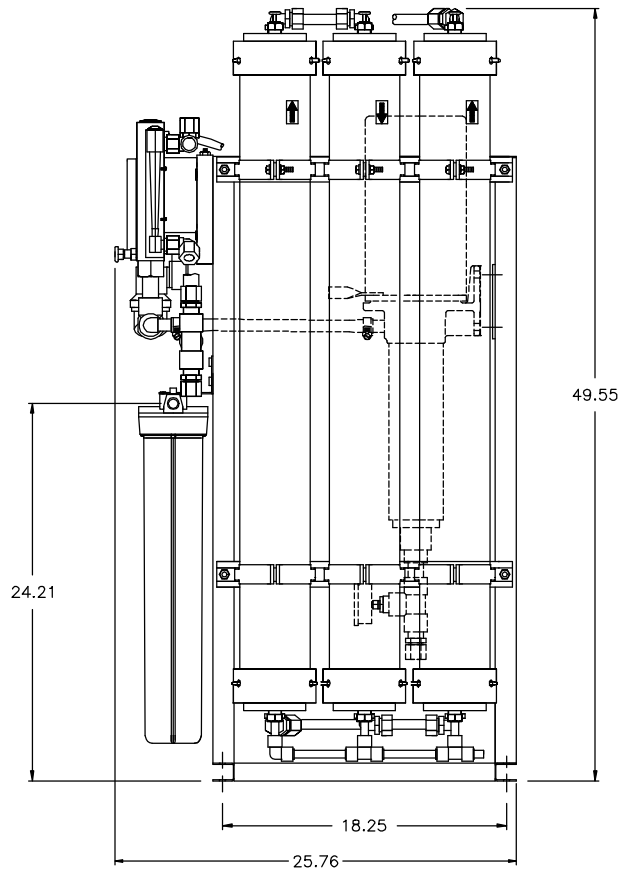

SIDE VIEW

NOTES:

- (1) ALL DIMENSIONS ARE GIVEN IN INCHES AND ARE APPROXIMATE.
- (2) MODEL AF-6 PLUS IS SHOWN.
- (3) ALLOW 45 INCHES ABOVE THE UNIT FOR SERVICING AND REPLACEMENT OF MODULES.
- (4) PROVIDE A DRAIN CAPABLE OF HANDLING AT LEAST 11 GALLONS PER MINUTE. DO NOT MAKE A DIRECT CONNECTION TO THE DRAIN. PROVIDE AN AIR GAP OF AT LEAST FOUR TIMES THE DIAMETER OF THE DRAIN PIPE TO CONFORM TO SANITATION CODES AND TO PERMIT THE OBSERVATION OF THE DRAIN FLOW. DO NOT INSTALL A VALVE IN DRAIN LINE OR USE PIPE SMALLER THAN LISTED IN TABLE.
- (5) PLUMBING CONNECTIONS:
 

|             |                         |                         |
|-------------|-------------------------|-------------------------|
|             | A-1 THROUGH A-3         | A-4 THROUGH A-6         |
| FEED        | 3/4" NPT                | 3/4" NPT                |
| PRODUCT     | 1/2" TUBE               | 5/8" TUBE               |
| CONCENTRATE | 1/4" TUBE               | 1/4" TUBE               |
|             | 1/2" TUBE (PLUS MODELS) | 1/2" TUBE (PLUS MODELS) |

|   |        |             |      |   |          |
|---|--------|-------------|------|---|----------|
| NORTHBROOK, ILLINOIS  |        |             |      |   |          |
| SCALE   | 00.00  | DETAILED BY | KMR  | CHECKED BY  | APPROVED |
| REF. NO.  | DATE   | DATE        | DATE | DATE  | DATE     |
| LET   | CHANGE | BY          | APP  | DATE  |          |
| PRINT & BILL OF MATERIALS ARE NOT TO BE USED WITHOUT THE WRITTEN CONSENT OF CULLIGAN USA<br>DO NOT SCALE FROM DRAWING |        |             |      | NAME<br>SERIES A<br>REVERSE OSMOSIS SYSTEMS<br>TECHNICAL DATA SHEET |          |
|   |        |             |      | PART NO.<br>RO_A1<br>SHEET 1 OF 2                                   |          |

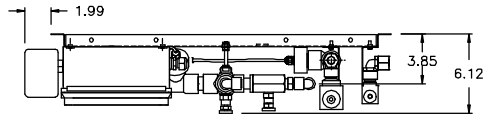

A- PLUS CONTROL ASSEMBLY (TOP VIEW)

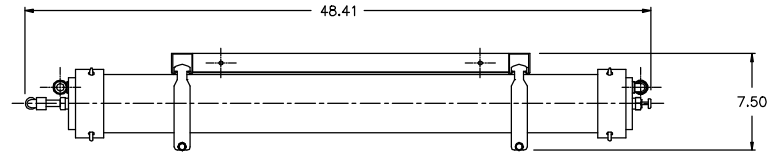

MODULE ASSEMBLY (TOP VIEW)

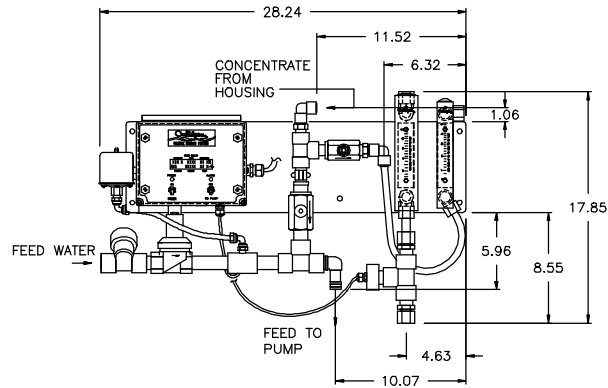

A- PLUS CONTROL ASSEMBLY (FRONT VIEW)

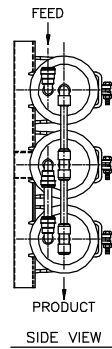

SIDE VIEW

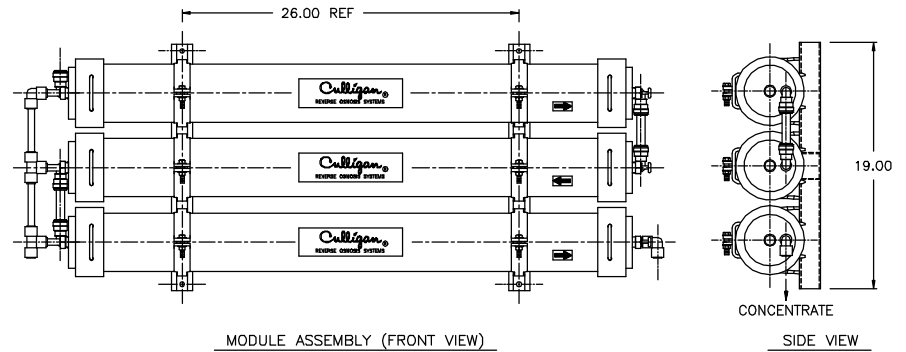

MODULE ASSEMBLY (FRONT VIEW)

SIDE VIEW

NOTES:

- (1) ALL DIMENSIONS ARE GIVEN IN INCHES AND ARE APPROXIMATE.
- (2) A PREFILTER IS PROVIDED AS PART OF THE UNIT. THE INSTALLER MAY WALL MOUNT THE 5" DIAMETER X 22" LONG PREFILTER TO ANY CONVENIENT LOCATION. THE PREFILTER HAS 3/4" NPTI CONNECTIONS.
- (3) ALLOW 45 INCHES ABOVE THE UNIT FOR SERVICING AND REPLACEMENT OF MODULES.
- (4) AN OPTIONAL BRACKET FOR WALL MOUNTING ON 16", 18" OR 20" CENTERS IS AVAILABLE FOR THE CONTROL AND MODULE ASSEMBLY. THE WALL MUST BE CAPABLE OF SUPPORTING AT LEAST 180 POUNDS (A-6 PLUS).
- (5) PROVIDE A DRAIN CAPABLE OF HANDLING AT LEAST 11 GALLONS PER MINUTE. DO NOT MAKE A DIRECT CONNECTION TO THE DRAIN. PROVIDE AN AIR GAP OF AT LEAST FOUR TIMES THE DIAMETER OF THE DRAIN PIPE TO CONFORM TO SANITATION CODES AND TO PERMIT THE OBSERVATION OF THE DRAIN FLOW. DO NOT INSTALL A VALVE IN DRAIN LINE.
- (6) PLUMBING CONNECTIONS:
 

|             |                         |                         |
|-------------|-------------------------|-------------------------|
|             | A-1 THROUGH A-3         | A-4 THROUGH A-6         |
| FEED        | 3/4" NPT                | 3/4" NPT                |
| PRODUCT     | 1/2" TUBE               | 5/8" TUBE               |
| CONCENTRATE | 1/4" TUBE               | 1/4" TUBE               |
|             | 1/2" TUBE (PLUS MODELS) | 1/2" TUBE (PLUS MODELS) |

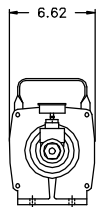

PUMP ASSEMBLY (SIDE VIEW)

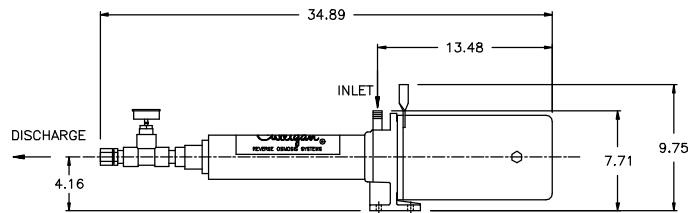

PUMP ASSEMBLY (FRONT VIEW)

|   |        |       |             |            |   |
|---|--------|-------|-------------|------------|---|
| <b>Culligan®</b>  |        |       |             |            |   |
| NORTHBROOK, ILLINOIS  |        |       |             |            |   |
| SCALE   |        | 00.00 | DETAILED BY | KMR        |   |
| REF. NO.  |        | DATE  | 3/8/99      | CHECKED BY | DATE  |
| LET   | CHANGE | BY    | APP         | DATE       | DATE  |
| PRINT & BILL OF MATERIALS ARE NOT TO BE USED WITHOUT THE WRITTEN CONSENT OF CULLIGAN USA<br>DO NOT SCALE FROM DRAWING |        |       |             |            | NAME<br>SERIES A<br>REVERSE OSMOSIS SYSTEMS<br>TECHNICAL DATA SHEET |
|   |        |       |             |            | PART NO.<br>RO_A2<br>SHEET 2 OF 2                                   |



# ENGINEER'S SPECIFICATION

|  |                  |
|--|------------------|
| <b>REVERSE OSMOSIS SYSTEM<br/>SERIES A AND SERIES A PLUS</b> | <b>CUSTOMER:</b> |
|  | <b>DATE:</b>     |

## 1.0 SCOPE

1.1 Provide as indicated a reverse osmosis system complete with modules, control system and prefilter. The system will be of an approved design as fabricated by a manufacturer regularly engaged in the production of water treatment equipment. All equipment and material will be supplied in compliance with the specifications as intended for a complete and operational system.

(Open Bidding Arrangement)

1.2 Qualified manufacturers of water treatment equipment of the type specified are Culligan International Company or the Engineer's approved equal.

(Closed Bidding Arrangement)

1.2 Qualified manufacturers of reverse osmosis equipment must be engaged in the manufacture of this equipment for a period of not less than fifteen (15) years. Acceptable manufacturers are Culligan International Company or the Engineer's approved equal.

## 2.0 GENERAL DESCRIPTION

(Selection for statement of specific model)

2.1 The system specifications are based on Culligan International model \_\_\_\_\_.

The purpose of the Culligan Series A reverse osmosis system will be to reduce the dissolved mineral salt content from a known water supply. The system will be capable, upon initial startup, of reducing the dissolved mineral salt content of the water by at least 97%, based on membrane industry design standards, when the system is operated in accordance with the operating instructions. The system will be capable of supplying \_\_\_\_\_ gallons of treated water per day based on the influent water analysis listed in Section 3.1 of this equipment specification.

There shall be a quantity of \_\_\_\_\_ of the above described systems.

(Selection for general statement)

2.1 The system, in compliance with the equipment specification, is described as an automatic **<single/duplex/triplex>** reverse osmosis system meeting the performance and design data requirements as hereinafter specified.

## 3.0 PERFORMANCE AND DESIGN DATA

### 3.1 INFLUENT WATER ANALYSIS

|                      |  |
|----------------------|--|
| Calcium, Ca: _____   | Chloride, Cl: _____                    |
| Magnesium, Mg: _____ | Nitrate (N): _____                     |
| Sodium, Na: _____    | Sulfate (SO <sub>4</sub> ): _____      |
| Potassium, K: _____  | Bicarbonate (HCO <sub>3</sub> ): _____ |
| Strontium, Sr: _____ | Carbonate (CO <sub>3</sub> ): _____    |
| Barium, Ba: _____    | Fluoride (F): _____                    |

(Constituents above are expressed in ppm or mg/l as CaCO<sub>3</sub> or as otherwise specified.)

|                                   |                      |                                    |
|-----------------------------------|----------------------|------------------------------------|
| Silica (SiO <sub>2</sub> ): _____ | Iron, Fe: _____      | Total Dissolved Solids, TDS: _____ |
| Total Chlorine: _____             | Manganese, Mn: _____ |                                    |

(Constituents above are expressed in ppm or mg/l.)

|                       |              |  |
|-----------------------|--------------|--|
| Turbidity, NTU: _____ | Color: _____ | Total Hardness, gpg as CaCO <sub>3</sub> : _____ |
| Temperature, °F _____ | pH: _____    | Silt Density Index (SDI): _____                  |

### 3.2 DESIGN PARAMETERS

|   |                          |     |
|---|--------------------------|-----|
| Nominal Capacity*:                      | _____                    | GPD |
| Approximate Recovery:                   | _____                    | %   |
| Daily Water Usage:                      | _____                    | GPD |
| Daily Hours of Water Demand:            | _____                    |     |
| Motor, HP:                              | 1.0                      |     |
| Operating Temperature Range:            | 33° – 100°F              |     |
| Max. Operating Pressure (Pump):         | 160 psi                  |     |
| Inlet Pressure (dynamic):               | 20 – 50 psig             |     |
| Electrical Requirements:                | 230 Volt, 60 Hz, 1 phase |     |
| System Dimension - Frame (L x W x H):   | 30"L x 26"W x 50"H       |     |
| Control Assembly Dimension (L x W x H): | 28.2"L x 6.1"W x 17.9"H  |     |
| Pump Assembly Dimension (L x W x H):    | 6.6"L x 34.9"W x 9.75"H  |     |
| Module Assembly Dimension (L x W x H):  | 48.4"L x 7.5"W x 19"H    |     |

*\*Approximate initial capacity is based on properly pretreated feed water of 600 ppm TDS as NaCl, 77°F, Silt Density Index below 3.0, and 140 psi applied pressure supplying water to atmosphere.*

### 3.3 EFFLUENT WATER QUALITY

Initial effluent water quality based on the analysis in section 3.1 is estimated to be \_\_\_\_\_ mg/l TDS.

## 4.0 EQUIPMENT SPECIFICATIONS

### 4.1 PREFILTER

The equipment will include one (1) replaceable element type prefilter. Each filter housing will be of polypropylene construction, will include an integral pressure relief valve and will contain one (1) prefilter cartridge. Each filter cartridge will be of polypropylene construction and rated at 5 microns nominal to assure maximum protection of the pump and modules.

### 4.2 PUMP

One pump and motor assembly will be provided to boost the incoming water to an operating pressure of 140 psig. Each multi-stage centrifugal pump will have a discharge flow of 11 gpm. Each pump will be close coupled to a 1 HP electrical motor operating at 230VAC/60HZ/1PH.

### 4.3 MODULES

The unit will use spiral wound reverse osmosis modules. The 4 inch diameter by 40 inch long modules will be the polyamide thin film composite membrane type. The module array will be capable, upon initial startup, of producing water at a nominal flow rate of \_\_\_\_\_ gallons per day based on Culligan equipment specifications as outlined in paragraph 3.2. The module assembly will consist of

- (A-1): One
- (A-2): Two
- (A-3): Three
- (A-4): Four
- (A-5): Five
- (A-6): Six

single element housing(s). The housings will be constructed of PVC for corrosion resistance.

Modules will be connected in a series, multi-stage arrangement so to deliver the design capacity with minimal waste flow requirements.

### 4.4 PIPE AND FITTINGS

The equipment will include all mechanical, hydraulic and electrical controls for a complete, self contained unit. A 0.75 inch normally closed solenoid valve will be mounted on the inlet to shut off the water supply when the unit is not operating.

#### 4.4.1 Operating Pressure Control Valve

Operating pressure will be controlled by a needle-type high pressure control valve mounted on the waste line of the modules. It will be constructed of corrosion resistant materials and be equipped with a knob for setting the operating pressure.

#### 4.4.2 Waste Restrictor

(Standard)

A fixed flow restrictor will be installed on the concentrate return of the control assembly to maintain the proper recovery ratio of product-to-feed water flow.

(Plus Systems)

A throttling valve will be installed on the concentrate return of the control assembly to maintain the proper recovery ratio of product-to-feed water flow.

#### 4.4.3 Pressure Gauge(s)

One liquid filled pressure gauge will be included. The gauge will indicate the operating pressure of the unit over the range of 0 to 160 psi.

#### 4.4.4 Flow Indicators

Two clear acrylic flow indicators will be mounted on the front of the control panel to show the rate of product flow and rate of waste flow.

#### 4.4.5 Hydraulic Connections

The system will be designed with a 0.75 inch hose connection to the inlet of the prefilter and a 0.75 inch hose connection from the prefilter to the feed connection on the unit. The product water connection will be **<0.5/0.625>** inch tube. The concentrate water connection will be **<0.25/0.5>** inch tube.

#### 4.4.6 Mounting

(Series A)

All components except the prefilter and pump, will be mounted on a 10 gauge steel frame suitable for wall mounting. Optional 14 gauge steel wall brackets are also available to simplify installation. An optional steel painted frame is also available for mounting the control assembly, pump assembly, module assembly and prefilter.

(Series AF)

The control assembly, pump assembly, module assembly and prefilter are mounted to a rigid 14 gauge steel frame and are completely pre-plumbed.

#### 4.5 ELECTRICAL CONTROLS

(All)

Operation of the unit will be controlled by a two position (ON-OFF) switch located on the front of the control panel. Connections will be provided to allow easy installation of an optional level control or pressure switch, which will shut down the system and prevent overflow or overpressurizing of an optional product water storage tank. A pressure sensing switch will be installed after the inlet solenoid to protect the pressure pump from cavitation by shutting down the pump and inlet solenoid should the inlet pressure fall below 8 psig for more than 3 seconds.

Connections will be provided to allow simplified wiring of an external signal switch, which will shut down the inlet solenoid and pressure pump during the regeneration cycle of pretreatment equipment to prevent untreated water from entering the reverse osmosis system. The system will start automatically when the pretreatment equipment has finished regeneration.

(Plus Systems)

An electronic controller will be utilized to control the logical operation of the unit. The enclosure will be hinged and watertight. Operational data will be displayed on a 2 line x 20 character backlit LCD alphanumeric display viewable on the front of the enclosure door. The first line of the display will indicate product TDS, feed TDS and percent rejection. If the unit is in a shutdown condition such as storage tank full, pretreatment lockout, high temperature alarm, low pressure alarm or poor quality alarm, the first line display will indicate the shutdown condition. The second line shall indicate the operating status, the elapsed time of operation and feed water temperatures.

The electronic panel shall control an optional line pressure flush during high storage tank level or shut down conditions with exception to high temperature alarm, all delay times for shut downs and flush are field programmable.

The TDS monitor will be temperature compensated and include a user adjustable relay to signal when quality falls below the desired level.

An audible alarm will indicate low pressure shutdown, high temperature shutdown, and poor product water quality conditions.

#### 4.6 ACCESSORIES

##### *(Standard Systems)*

- 4.6.1  A quality monitor will be provided to monitor product water quality to service.
- 4.6.2  A flow meter will be provided to monitor product water flow.
- 4.6.3  A painted steel frame assembly will be provided for mounting of the RO components.
- 4.6.4  Wall mounting brackets to mount the Control and Module Assembly.
- 4.6.5  Two pressure gauges will be provided to measure the inlet and outlet pressure of the prefilter cartridge.
- 4.6.6  Concentrate throttling valve.

##### *(Plus Systems)*

- 4.6.1  A painted steel frame assembly will be provided for mounting of the RO components.
- 4.6.2  Wall mounting brackets to mount the Control and Module Assembly
- 4.6.3  Two pressure gauges will be provided to measure the inlet and outlet pressure of the prefilter cartridge.

#### 5.0 INSTRUCTIONS

\_\_\_\_\_ complete sets of installation, operating and maintenance manuals shall be provided.

#### 6.0 FIELD SERVICE

The services of a factory authorized service representative can be made available to supervise, inspect and provide operator training as required for initial start-up and system operation. Contact your local Culligan dealer for service rates and scheduling.

#### 7.0 WARRANTY

All mechanical equipment shall be warranted for a minimum of one (1) year against any defects in workmanship or materials. All electronic equipment shall be warranted for one (1) year against any defects in workmanship or function. A single written warranty must be provided from the manufacturer of the reverse osmosis system.